

# 2160

## Hydraulic Boom Rotary Cutter



 Max Vertical Reach of 22'6"

 Max Horizontal Reach of 21'

 190° Cutter Head Range

 Available in 540 Rpm

 2" Cut Capacity

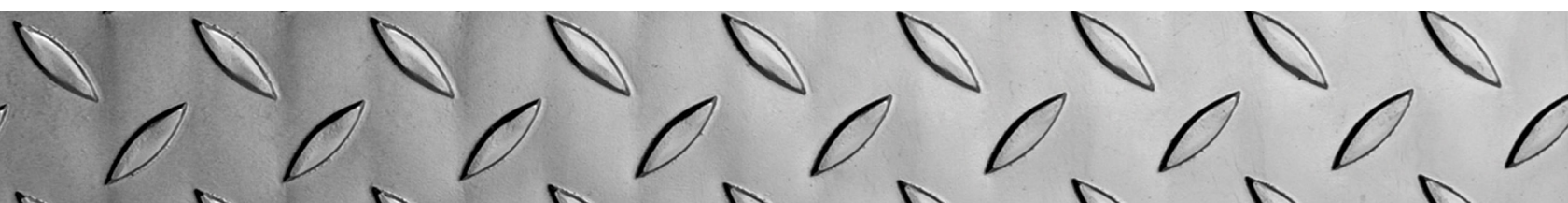
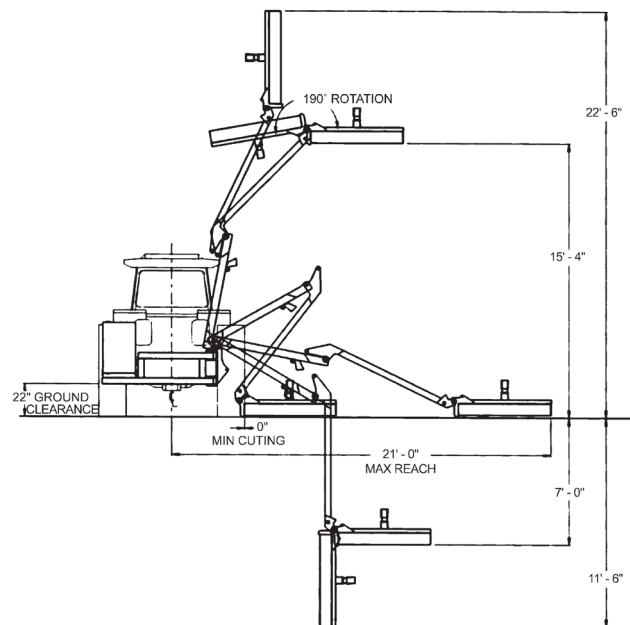

# 2160

## SPECIFICATIONS

### STANDARD EQUIPMENT & SPECIFICATIONS

Cutting Width:	60"
Transport Width:	113"
Overall Width (Head):	69"
Overall Length (Head):	71 3/8"
Cutting Height (Min):	1 3/4"
Support Stand:	Std
Hitch:	CAT 2 & 3 QH
Blade Carrier:	Pan
Blades:	1/2" x 4" Updraft
Blade Rotation:	Clockwise
HP Required:	110 PTO w/ Adequate Front & Side Weights
PTO Type:	540 RPM Only
Oil Reservoir Capacity:	55 Gallons Factory Filled
Max Operating Pressure:	3,000 PSI
Breakaway Pressure:	2,750 PSI
Blade Tip Speed:	16,870 FPM
Horizontal Reach (Max):	21'
Vertical Reach (Max):	22' 6"
Down Reach (Max):	11' 6"
Cutting Capacity (Max):	2"
Driveline Size:	CAT 4
Overload Protection:	Hydraulic Relief Valve
Deck Thickness:	10 Ga
Side Skirt:	10 Ga x 9 1/4"
Range of Head Movement:	190 Degrees
Hydraulic Pump Rating:	18.32 GPM
Protective Cage:	Required for Non-Cab Tractors
Safety Deflectors:	Rubber Belting
Weight (Approx):	2,700 lbs (w/ Oil)

**Gearbox Rating Based on Field Performance**



*Shown with Extra Equipment  
Joystick Shown below*

