



AXIAL-FLOW®

50 SERIES COMBINES

PREVIEW BROCHURE



INTRODUCING THE AXIAL-FLOW 250 SERIES COMBINES.

With 250 series Axial-Flow combines, you get the latest advancements, without sacrifice. Case IH offers the industry's largest lineup of combines to meet the needs of any operation. From header to spreader, Axial-Flow series combines are designed to be reliable and preserve the quality of more than 134 grain types, so you can simply harvest more of what you grow. Now that's high-efficiency harvesting.

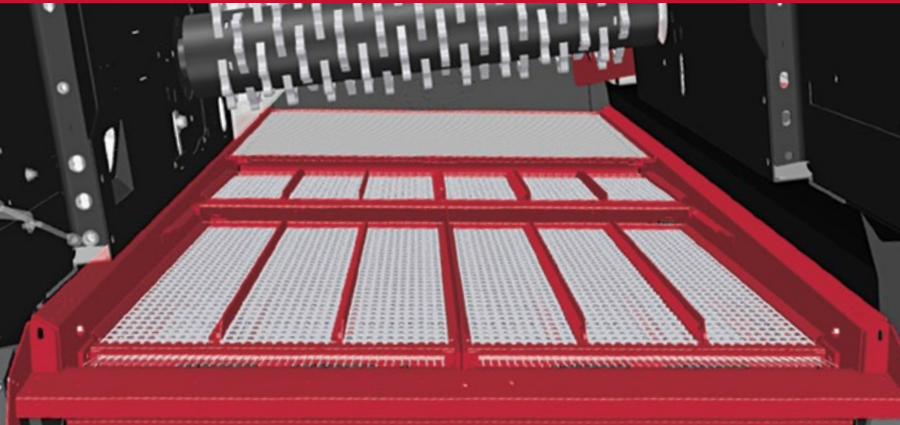

Adjustable cage vanes in base.
In-cab adjustable cage vanes optional.

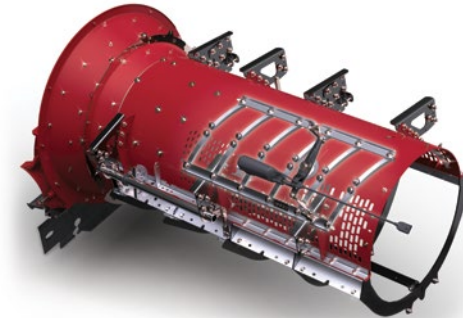

Adjustable cage vanes provide the operator the ability to optimize threshing and separating.

SELF-LEVELING CLEANING SYSTEM.

The self-leveling cleaning system (SLS), standard on Axial-Flow 250 series combines, saves grain and increases productivity on flat ground as well as on hills. The entire system (grain pan, top sieve, bottom sieve and fan) levels itself for optimum cleaning efficiency on flat fields or hills and banks on end row turns, minimizing potential grain loss.

Axial-Flow combines lead the industry in cleaning area. In each class size, the Axial-Flow cleaning area is larger, delivering cleaner samples with minimal losses and matched capacity.

The 250 series now includes an in-cab adjustable pre-sieve that allows the operator to make adjustments on the go, which help maximize grain quality.

■ **Active grain pan.** Designed for extra capacity, an active grain pan is utilized on the Axial-Flow 250 series combines. The active grain pan helps stratify material, leaving the heavy seeds at the bottom of the pan and the lighter MOG (material other than grain) at the top. When the layers move onto the sieves, the grain falls and the MOG is lifted in the air by the Cross-Flow cleaning fan.

ADVANCING SINGLE-ROTOR DESIGN.

The AFX rotor features constant pitch impellers that draw the crop and air into the rotor. The AFX rotor can be set in many configurations, adapting to both crop and threshing conditions with the use of straight bars, spiked rasp bars and helical kickers. Competitive rotor and cage designs can reduce productivity and increase grain damage because of inefficient feeding and crop-control designs.

- **Transition cone.** The transition cone is a patented feature of Axial-Flow series combines. Its simple geometry transitions crop from feeder to rotor. Crop smoothly accelerates in a spiral motion from 5 mph to about 60 mph.
- **Concave/module wrap.** Concave/module wrap is one of the most important elements affecting combine capacity. While other brands use longer rotors, Case IH uses the concave/module wrap to gain capacity. All Case IH combines use a 30-inch diameter rotor. The Axial-Flow 150 series uses 156 degrees of concave wrap while the 250 series utilizes 180 degrees of module wrap.
- **New adjustable cage vanes.** Available on the 250 series, optional in-cab adjustable cage vanes adapt the threshing system to changing loads and crop conditions. This helps maximize throughput and optimize grain savings. The standard feature includes a gang of cage vanes that are manually adjustable with an easy turnbuckle handle.

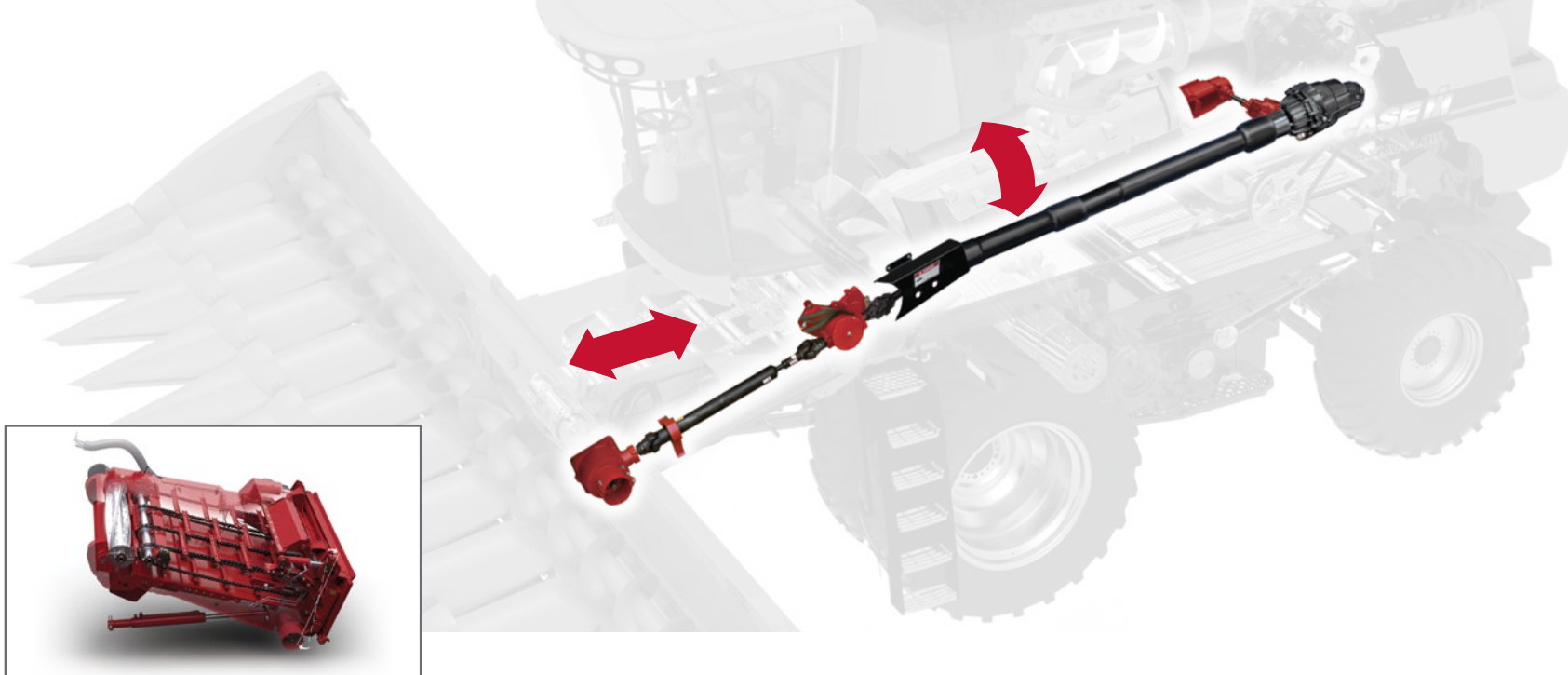

REDESIGNED FEEDER HOUSE.

High-capacity features and heavy-duty feeding systems help ensure a smooth harvest. 250 series combines include optional advancements to the feeder house, such as a heavy-duty feeder lift capacity to handle up to 18-row narrow chopping corn heads, high-capacity feeder drive and fore/aft feeder faceplate tilt. Additional improvements include header height control software, and improved feeder top-shaft reliability. The result is even smoother crop flow and greater durability.

New features for 2019 include:

- Optional feeder face fore/aft control allows you to make adjustments from the cab.
- Redesigned feeder top shaft drive coupler features a crowned spline design for greatly improved durability and reliability.
- A simple two-piece feeder floor design increases durability and improves crop feeding.

2-SPEED ELECTRIC SHIFT GROUND DRIVE.

This new transmission simplifies operation so you can use first gear for harvest and second gear for roading. Additional features include:

- Delivers wider speed ranges for more power for climbing hills and propulsion through challenging ground conditions.
- Reduces the need to stop and shift in field or on road.
- Uses a hi/low propulsion system to toggle between low and hi ranges during harvest. This provides additional operator control when extra traction or change in speed is required.
- Uses closed-loop sensing for constant speed control (like cruise control in a car).
- Provides greater torque through a wider speed range without shifting due to increased displacement of pumps and motors.
- Improves traction and field performance with optional differential lock that is electrically actuated and hydraulically engaged.
- Provides enhanced road mode features to:
 - Improve fuel savings during transport
 - Maximize fuel savings with economy mode and auto-idle RPM to automatically adjust engine RPM

PATENTED, REVOLUTIONARY POWER PLUS CVT DRIVES.

Our innovative Power Plus™ continuously variable transmission (CVT), pioneered and patented for more than 10 years, features a belt-free, low-maintenance design with variable speed drives and unique in-field capabilities, including rotor de-slug and our patented corn head to groundspeed syncing that helps save time, boost productivity and deliver the ultimate in operator control.

CVT drives are specifically built to accommodate the higher horsepower demands of our 7250, 8250 and 9250 series combines. It's an exclusive technological advancement you won't find on any other manufacturer's machines. The three-speed rotor gearbox optimizes the speed range for peak efficiency. With a CVT drive, you get the convenience of hydraulic variable control and the efficient power transfer of a mechanical system. Plus, unique in-field capabilities like patented header to groundspeed syncing for corn heads, ensures smooth material flow from header to spreader.



9250

CASE IH
AXIAL-FLOW

CASE IH

INTRODUCING AFS HARVEST COMMAND™ — WELCOME TO HIGH-EFFICIENCY HARVESTING.

Significant advancements in combine automation, and available only on the 250 series Axial-Flow combines, lead the way in the future of harvesting technology. AFS Harvest Command automation proactively adjusts the combine as crop conditions change using exclusive, patent-pending technology. You choose the level of automation from four modes of performance. From there, Harvest Command automation, with its 16 sensors throughout the machine take over controlling seven combine adjustments. This technology helps the inexperienced operator achieve the productivity of an expert operator.



CHOOSE FROM FOUR MODES OF AUTOMATION TO FIT YOUR OPERATION.

- **Performance:** Maximize grain savings and grain quality while optimizing throughput.
- **Grain Quality:** Maximize grain quality while also saving grain and optimizing throughput.
- **Max throughput:** The operator can maximize throughput while automation adjusts combine settings to save grain.
- **Fixed throughput:** The operator can fix the machine throughput and the machine will adjust to save grain and maintain a quality sample.

MAKE EVERY DRIVER AN EXPERT OPERATOR.

Fine-tuning harvest settings and adjustments can test even the most experienced operator. AFS Harvest Command automation helps refine the harvesting process by reducing the number of functions you need to monitor in the cab from 12 to three. With AFS Harvest Command, you control concave clearance, header position, and grain tank unload while the automation system takes care of the rest for you.

BOOST PRODUCTIVITY WITH OPTIMAL SETTINGS.

For expert operators, AFS Harvest Command allows you to be more relaxed as conditions change and improve output and grain quality.

FIRST CUSTOMER REACTIONS.

“Labor is important. Whether you’ve run a combine for 50 years or 50 minutes, this machine is super user-friendly. The fact you can grab someone off the street and get the same results as someone that has run one forever is extremely appealing to us.”

— **Mark Bartlett**
Colby, Kansas

Running an Axial-Flow 8250 combine with 3162 draper head.

FIND YOUR PERFECT FLOW WITH AFS HARVEST COMMAND.

Regardless of the time of day, crop conditions or moisture levels, AFS Harvest Command is always working for you. It's simple, just choose the mode of automation to match your harvesting goals. From there, AFS Harvest Command takes over. Each automation mode prioritizes different harvesting outcomes — from grain quality, to grain savings, to throughput — and continually optimizes machine performance based on the limits set by the operator.

PERFORMANCE MODE.

- Automation to achieve maximum grain savings and grain quality while optimizing throughput.
- **Situation:** The harvest season is progressing well. Conditions are nearly ideal, with no weather threats looming. Your aim is to hit the sweet spot that optimizes grain savings, grain quality and throughput.



GRAIN QUALITY MODE.

- Automation to achieve maximum grain quality in the tank, while also saving grain and optimizing throughput.
- **Situation:** Your goal is to deliver the highest-quality grain possible, perhaps to earn premiums for food-grade grains or seed crops. Minimizes cracked and broken kernels, while providing a clean grain sample.





MAX THROUGHPUT MODE.

- The operator can maximize the throughput and the machine will adjust to save grain and maintain a quality sample.
- **Situation:** Harvest is at a critical juncture. The forecast is a concern. It's time to wrap up harvest. You need to maximize the acres you harvest each day without sacrificing grain loss or quality.



FIXED THROUGHPUT MODE.

- The operator can fix the machine throughput and the machine will adjust to save grain and maintain a quality sample.
- **Situation:** Steady progress wins the harvest. Your workforce includes less-experienced combine operators. Rather than asking those operators to fine-tune settings and operation — potentially leading to unacceptable grain loss or damage — set a consistent, steady pace and maximize your quality of work.

150 SERIES — A LOOK TO THE FUTURE; A NOD TO THE PAST.

Axial-Flow 150 series combines feature the legendary single-rotor technology, combined with the Cross Flow™ cleaning system and increased grain-handling capacity, to put more high-quality grain in the tank. Now, you can bring a piece of the IH legacy to your farm with this special-edition heritage combine. These heritage models are a salute to the original Axial-Flow combine that revolutionized the combine industry when launched. In addition, the 150 series recognizes the advancements made to the combine productivity, such as the Cross Flow cleaning system, the two-speed electric shift transmission, the increased grain-handling capacity, and the hydraulically driven residue package. Also new for 2019 is the option of a differential lock on the 2-speed transmission.



CELEBRATE THE LEGACY OF AXIAL-FLOW COMBINES.

To commemorate the legacy of Axial-Flow combines, all Model Year 2019 150 series combines come with a special edition heritage paint scheme. Reminiscent of the original 1977 combine, the retro paint job features the IH grain tank decal, side panel model decals, and a white roof and rims.

ALL THE FEATURES YOU TRUST AND RELY ON.

■ Cross Flow Cleaning System:

- Increases productivity up to 20 percent
- Largest cleaning system in the industry for Class V to VII combines
- Auger bed with six extended-wear augers
- Patented Cross-Flow fan (450 to 1,300 rpm fan range)
- Cross Flow cleaning system compensates for hillsides; designed to maximize cleaning capacity up to 12 degrees
- Provides increased capacity even on level ground

■ 2-speed electric shift transmission:

- Provides 1st gear for harvesting and 2nd gear for roading
- Hi-low propulsion system provides the ability to shift from low to hi range in the field and on the go
- Provides increased propulsion and improved tractive effort for adverse field conditions and to pull out of fields and onto roads easier.

■ Residue management system:

- Three chopper options: 3-bladed discharge beater; standard cut straw chopper; 6-row flail cut chopper
- Standard dual-disc spreaders

■ High-capacity harvesting:

- Clean grain elevator handles up to 5,000 bu. per hour

■ AFX rotor:

- Creates smooth crop flow
- Improves throughput
- Puts more high-quality grain in your tank
- 156 degrees of concave wrap
- Split concaves weigh 38 pounds each
- Adjustable cage vanes improve threshing and throughput



150 SERIES SPECIFICATIONS	AXIAL-FLOW 5150	AXIAL-FLOW 6150	AXIAL-FLOW 7150
Combine Class Size	Class V	Class VI	Class VII
ENGINE			
Type - Tier 4 B/Final	Case IH - FPT		
Displacement	6.7 L (409 cu. in.)	8.7 L (531 cu. in.)	
Horsepower (Rated/Maximum)	265 hp (198 kW)/308 hp (230 kW)	348 hp (260 kW)/411 hp (306 kW)	375 hp (280 kW)/442 hp (330 kW)
Power Rise	43 hp (32 kW)	63 hp (47 kW)	67 hp (50 kW)
Unload Boost - Power on Demand	N/A	34 hp (25 kW)	
Fuel Tank/DEF Tank Capacity	250 gal. (945 L)/43 gal. (166 L)		
FEEDER			
Feeder Width	45.5 in. (1 156 mm)		
Feeder Length w/o Rock Trap	45 in. (1 143 mm)		
Feeder Drive Type	Belt		
Reverser System	Hydraulic		
Head Lift Cylinders Standard/Optional	2.95 in. (75 mm)/N/A	3.15 in. (80 mm)/3.35 in. (85 mm)	
Lateral Tilt Range Optional	+/- 5 degrees		
Stone Trap (Opt)	Beater/Sump		
THRESHING/SEPARATING			
Threshing Type	Rotary		
Rotor Drive Type/Rotor Diameter	Belt Drive/30 in. (762 mm)		
Rotor Speeds	250 – 1150 rpm		
# of Concave/Modules	6		
Threshing/Separating Area Wrap	156.5°/133°		
Separating Grates/Modules	3		
Discharge Beater Standard/Optional	Integral chopper/beater and chopper options available		
Auger Bed	Yes		
Active Grain Pan	No		
Grain Loss Monitor	Standard Equipment		
CLEANING SYSTEM			
Cleaning System Width	58 in. (1 473 mm) fixed cleaning system / 56 in. (1 422 mm) CrossFlow Cleaning System		
Total Sieve Area	8,556 sq. in. (5.52 m ²) fixed cleaning system / 8,370 sq. in. (5.40 m ²) CrossFlow Cleaning System		
Fixed or Self-Leveling Cleaning System	Fixed or CrossFlow		
Cleaning Capability % Slope (Degrees)	N/A fixed / 12° CrossFlow		
Sieve Louver Adjustment (In-Cab/Manual)	Standard/N/A		
Cleaning Fan Type/Drive	CrossFlow/Belt Variator		
Fan Speed Range	450 – 1,300 rpm		
Fan Diameter	11.4 in. (290 mm)		
CONVEYING AND STORAGE			
Tailings Elevator	Tailings return to rotor		
Clean Grain Elevator (Dimensions/Capacity)	9 × 15.9 in. (229 × 404 mm) / 5,000 bu/hr.		
Grain Tank Capacity	250 bu. (8 810 L)	300 bu. (10 570 L)	
Unloading Auger Length	21.5 ft. (6.55 m)	25.8 ft. (7.86 m)	
Unloading Rate	2.5 bu. (88 L) per second	3.2 bu. (113 L) per second	
DIMENSIONS			
Wheel Base - 2WD Axle / Pra Opt.	150.2 in. (3 815 mm)/150.2 in. (3 815 mm) - PGA		
Width (Overall Single Tires 120-in. Tread)	153.9 in. (3 909 mm)	150.9 in. (3 833 mm)	
Minimum Weight (2WD and Single Drive Tires)	33,715 lbs. (15 293 kg)	34,130 lbs. (15 481 kg)	34,850 lbs. (15 808 kg)
Typical Weight (2WD and Dual Drive Tires)	36,715 lbs. (16 664 kg)	37,130 lbs. (16 842 kg)	37,850 lbs. (17 168 kg)
Cab Height	153.6 in. (3 901 mm)	153.8 in. (3 907 mm)	

250 SERIES SPECIFICATIONS	AXIAL-FLOW 7250	AXIAL-FLOW 8250	AXIAL-FLOW 9250
Combine Class Size	Class VII	Class VIII	Class IX
ENGINE			
Type - Tier 4 B/Final	Case IH - FPT		
Displacement	11.1 L (677 cu. in.)	12.9 L (787 cu. in.)	16.0 L (970 cu. in.)
Horsepower (Rated/Maximum)	402 hp (299 kW)/468 hp (349 kW)	480 hp (358 kW)/555 hp (414 kW)	550 hp (410 kW)/625 hp (466 kW)
Power Rise	66 hp (49 kW)		75 hp (56 kW)
Unload Boost - Power on Demand	66 hp (49 kW)		75 hp (56 kW)
Fuel Tank/DEF Tank Capacity	297 gal. (1124 L)/43 gal. (166 L)		317 gal. (1200 L)/43 gal. (166 L)
FEEDER			
Feeder Width	54 in. (1372 mm)		
Feeder Length w/o Rock Trap	94 in. (2388 mm)		
Feeder Drive Type	CVT drive		
Reverser System	CVT hydraulic		
Head Lift Cylinders	2.95 in. (75 mm)/3.5 in. (90 mm)/3.7 in. (95 mm)		
Lateral Tilt Range Optional	+/- 5 degrees		
Fore/Aft Faceplate Tilt Optional	12 degrees		
Stone Trap (Opt)	Spiral Beater/Sump		
THRESHING/SEPARATING			
Threshing Type	Rotary		
Rotor Drive Type/Rotor Diameter	CVT Drive/30 in. (762 mm)		
Rotor Speeds	220 – 1180 rpm		
Number of Concave/Modules	2 pair		
Threshing/Separating Area Wrap	180°/180°		
Separating Grates/Modules	2 pair		
Discharge Beater Standard/Optional	Integral chopper/beater and chopper options available		
Auger Bed	No		
Active Grain Pan	Yes		
Grain Loss Monitor	Standard equipment		
Cage Vanes Standard/Optional	Manual adjust with turn buckle / In-cab adjustable		
CLEANING SYSTEM			
Cleaning System Width	62 in. (1575 mm)		
Total Sieve Area	10,075 sq. in. (6.9 m ²)		
Fixed or Self-Leveling Cleaning System	Self-leveling		
Cleaning Capability % Slope (Degrees)	12.1% (7.0°)		
Sieve Louver Adjustment (In-Cab/Manual)	Standard/N/A		
Cleaning Fan Type/Drive	CrossFlow/hydraulic		
Fan Speed Range	300 – 1150 rpm		
Fan Diameter	15.4 in. (391 mm)		
CONVEYING AND STORAGE			
Tailings Elevator	Tri sweep crop processor		
Clean Grain Elevator (Dimensions/Capacity)	11.9×10.4 in. (302×264 mm)/6,500 bu/hr.		
Grain Tank Capacity Standard/Optional	315 bu. (11100 L) / 410 bu. (14448L)		410 bu. (14448 L)
Unloading Auger Length	28 ft. 9 in. (8.8 m)		
Unloading Rate	4.0 bu. (141 L) per second		4.5 bu. (159 L) per second
DIMENSIONS			
Wheel Base - 2WD Axle / Pra Opt.	147.7 in. (3752 mm)/148.5 in. (3772 mm) - PGA		
Width (Overall Single Tires 120-in. Tread)	152 in. (3861 mm)		156 in. (3962 mm)
Minimum Weight (2WD and Single Drive Tires)	42,245 lb. (19162 kg)	42,845 lb. (19434 kg)	43,790 lb. (19863 kg)
Typical Weight (2WD and Dual Drive Tires)	46,378 lb. (21037 kg)	46,979 lb. (21309 kg)	47,924 lb. (21738 kg)
Cab Height	153.5 in. (3899 mm)		153.7 in. (3904 mm)
TECHNOLOGY			
AFS Connect Advanced with 2 Way File Transfer Combine Automation Standard/Optional	No automation / AFS Harvest Command		



SAFETY NEVER HURTS!™ Always read the Operators Manual before operating any equipment. Inspect equipment before using it, and be sure it is operating properly. Follow the product safety signs, and use any safety features provided. CNH Industrial America LLC reserves the right to make improvements in design and changes in specifications at any time without notice and without incurring any obligation to install them on units previously sold. Specifications, descriptions and illustrative material herein are as accurate as known at time of publication, but are subject to change without notice. Availability of some models and equipment builds varies according to the country in which the equipment is used.

©2018 CNH Industrial America LLC. All rights reserved. Case IH is a trademark registered in the United States and many other countries, owned by or licensed to CNH Industrial N.V., its subsidiaries or affiliates. Any trademarks referred to herein, in association with goods and/or services of companies other than CNH Industrial America LLC, are the property of those respective companies. Printed in U.S.A. www.caseih.com CIH18072301